

0.5 LAYER 900SD - REMOTE ACCESS UNIT ACCESS POINT CROSS SECTION
NTS

- NOTE 1: Ventilation may be crucial to reducing the pressure build up within the system. If solid access covers are used, alternative methods of ventilation are recommended.
- NOTE 2: Concrete Load Plates should contact/bond to the Remote Access Cover. A gap or bond break is recommended between cast-in-place concrete and the extension shaft. Consult Engineer of Record for additional requirements.
- NOTE 3: The 900SD Remote Access Unit is approximately the size of half of a half-module. The half-module throughout the tank height must be cut in half to accommodate the Remote Access Unit.
- NOTE 4: The 900SD Remote Access Unit has two configurations of template holes side walls. Both configurations are provided on each 900SD Remote Access Unit - two sides for each configuration. The two configuration options are depicted in this cross section.
- NOTE 5: Contractor to cut template holes on interior side walls and bottom of top 900SD Remote Access Unit to allow water flow and tank access. Unless otherwise specified in the project drawings, cut 15" diameter template holes on 900SD Remote Access Units on the three interior sides.

REMOTE ACCESS UNIT PIPE DIAMETER CHART

Nominal Template Hole Diameter (inches)					
4	6	8	10	12	15

- NOTE 1: Cut inlet / outlet pipe hole prior to Remote Access Unit installation.
- NOTE 2: Pipe diameters apply to thin-wall pipes. Contact ACO for guidance with other pipe types.
- NOTE 3: Contact ACO for guidance for inlet / outlet pipes larger than 15-inch diameter.

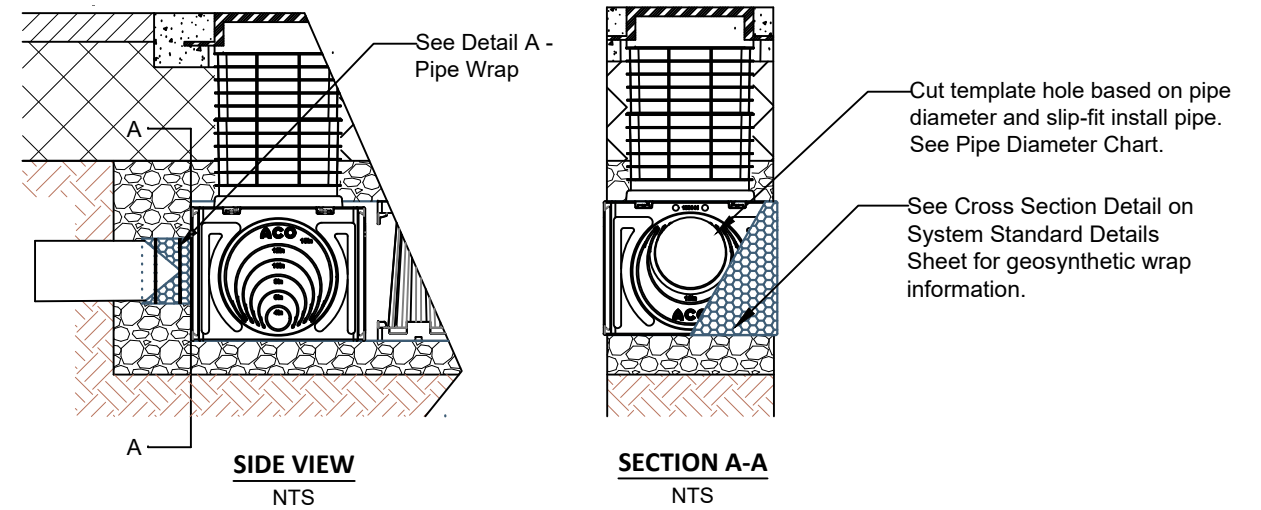

0.5 LAYER 900SD - REMOTE ACCESS UNIT PIPE INSTALLATION
NTS

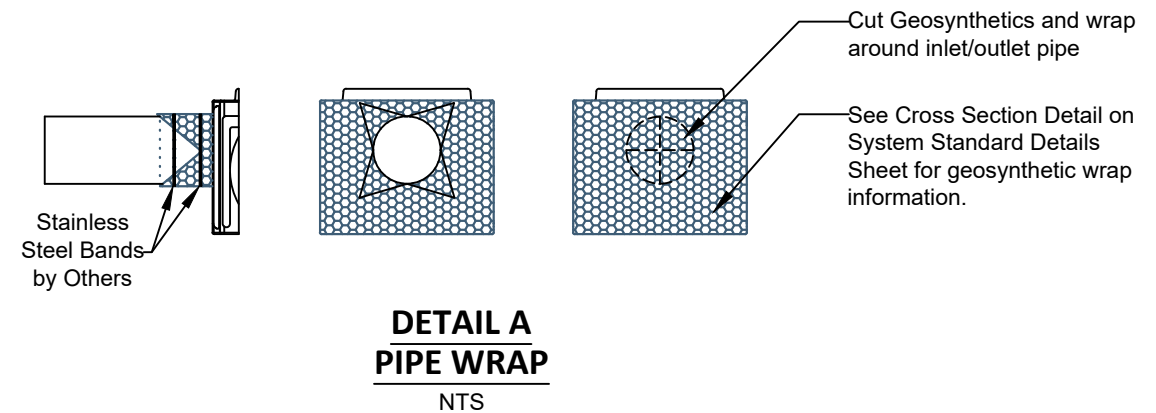

**DETAIL A
PIPE WRAP**
NTS

DRAWN BY K Chejarla	CHECKED BY A Frye
DATE 10/08/2025	REV. 0

STORMBRIXX STANDARD DETAILS
900SD SYSTEM - 0.5 LAYER REMOTE ACCESS UNIT



WEST SALES OFFICE
825 W BEECHCRAFT ST.
CASA GRANDE, AZ 85122
Tel. (888) 490-9552
Fax (520) 421-9899

EAST SALES OFFICE
9470 PINECONE DRIVE
MENTOR, OH 44060
Tel. (800) 543-4764
Fax (440) 639-7235

SOUTHEAST SALES OFFICE
481 MUNN RD. SUITE #225
FORT MILL, SC 29715
Tel. (440)-639-7230
Fax (803)-802-1063

www.acoswm.com